

Circular Saw™ Mountings



Features

The metal interleaf incorporated in the design provides a higher compression to shear stiffness ratio, thereby increasing the load capacity in the compression or combined compression and shear modes.

The 17-1780 engine mounting features a void in the rubber section to allow the use of a central snubber device.

Metalastik® type Circular SAW™ Mountings

Used in a variety of industrial applications including vibratory rollers and small screens and for the suspension of smaller engines.

17-1780 can be fitted with a rebound washer for mobile applications.

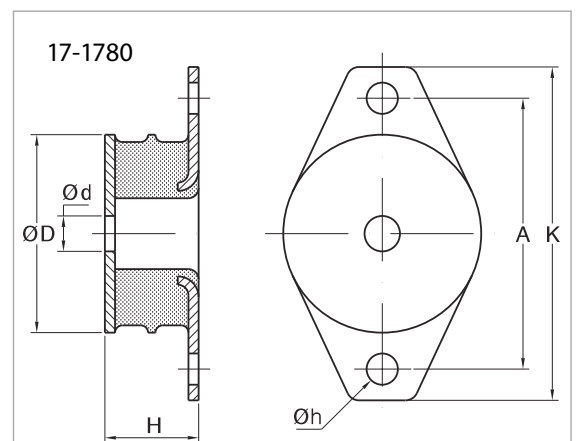
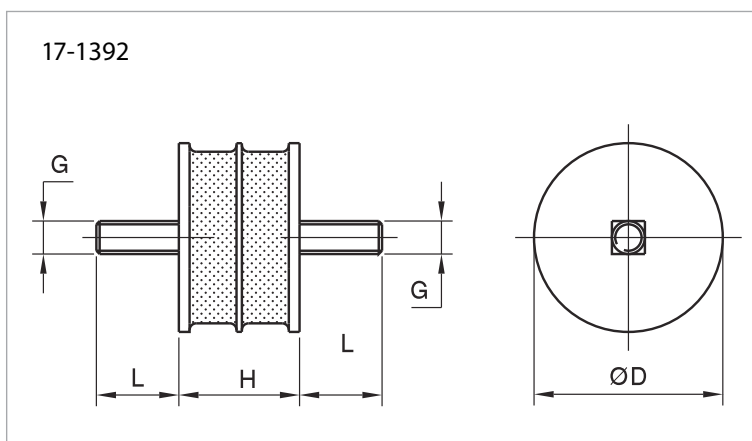

Drawing no.	Part no.	Dimensions in mm								Max load in compression (Kg)	Max load in shear (Kg)	Weight (Kg)
		D	H	L	G	A	K	d	h			
17-1392	10-00492	57	37	25	M10					120	90	0,28
17-1392	10-00493	57	37	25	M10					250	90	0,28
17-1392	10-00494	57	37	25	M10					330	90	0,28
17-1780	20-02536	95	45			130	160	17	15	190	135	0,81
17-1780	20-02848	95	45			130	160	17	15	380	160	0,81

Circular Saw TM Mountings

Note: The natural frequencies and degrees of isolation are based on dynamic characteristics of the mountings.

