

Multigate

MH16 F 17-1

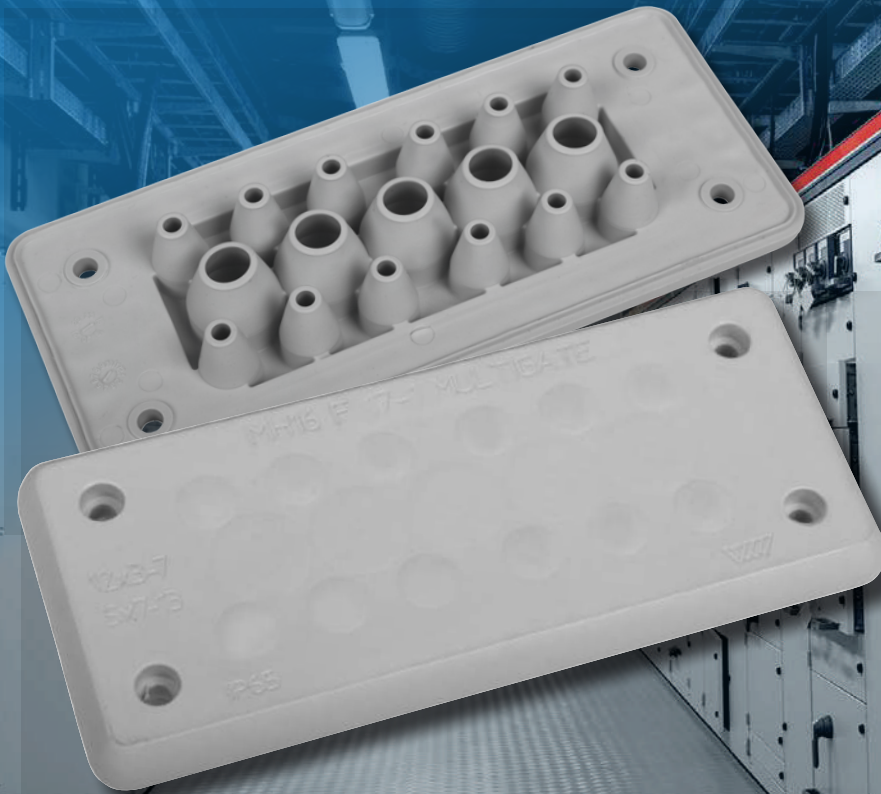

Multigate MH16 F 17-1 is a new plastic reinforced cable gland suitable for leading through cables and various types of tubing. It matches the cut out dimensions of 16-pole standard industrial connectors. No separate gasket is needed.

This Multigate gives total protection against ingress of dust and against water splashed from all directions. It is suitable for both indoor and outdoor use. IP classification is IP65, and the materials are fire retardant and halogen free.

Multigate MH16 F 17-1 will lead through and seal cables as follows:

3 – 7 mm	12 pcs
7 – 13 mm	5 pcs

Code	Colour
107292	Black
107295	Light Grey

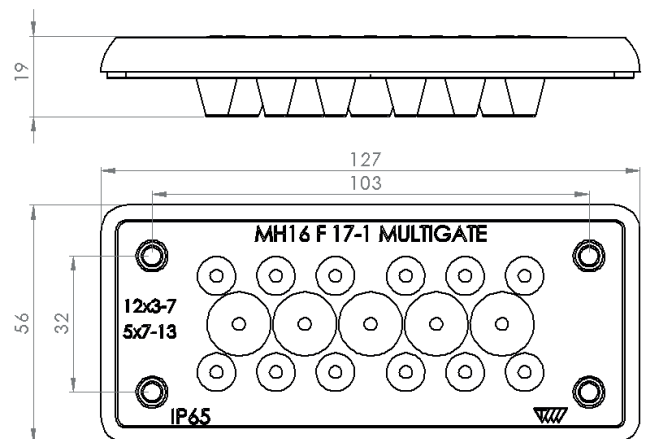

Flexico Technische Handelonderneming B.V.

Achterzeedijk 57-8
2992 SB Barendrecht
The Netherlands

Phone: +31 (0)180 624 589
Fax: +31 (0)180 690 758
Email: sales@flexico.nl

