

# Fanflex™



## Features

Simple design with metal parts encapsulated in high grade natural rubber compound giving good environmental resistance.

Provides relatively large static deflections and hence a high degree of vibration attenuation - 90% isolation for disturbing frequencies of 15 Hz ( 900 c.p.m ).

Range gives capacity for point loads of 35 kg to 350 kg.

## Metalastik® type Fanflex™

A simple mounting designed predominantly for the suspension of heating, ventilating and air conditioning equipment.

May be used for:  
Pumps, fans, compressors and control cabinets.

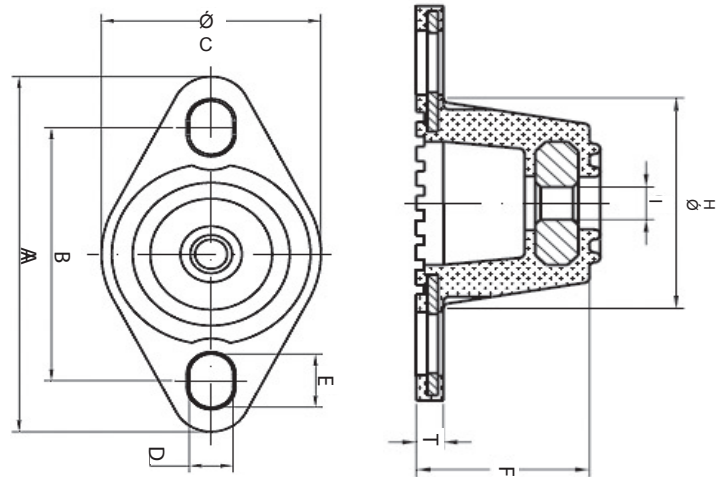

Dimensions	A mm	B mm	C mm	D mm	E mm	F mm	G mm	H mm	I mm	Weight G
<b>S</b>	80	57	45	9	12	32	5	41	M8	85
<b>M</b>	95	71	60	9	14	45	5	56	M10	220
<b>L</b>	150	115	86	11	22	70	6	82	M12	660

Measure	Type-no.	Colour code	Stiffness N/mm	Load N
<b>S</b>	32-0035-08	Yellow	45	80 - 300
	32-0065-08	Blue	80	150 - 500
	32-0100-08	Red	125	300 - 750
<b>M</b>	32-0130-10	Yellow	130	160 - 850
	32-0225-10	Blue	225	300 - 1400
	32-0350-10	Red	350	600 - 2000
<b>L</b>	32-0185-12	Yellow	180	250 - 1500
	32-0320-12	Blue	300	450 - 2500
	32-0500-12	Red	500	1000 - 3500